

4 | 3 | 2 | 1

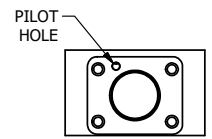

POSITION GASKET AND PEC3-18 ON END OF VALVE TO ALIGN PILOT HOLES (SIDE 'B' ONLY)

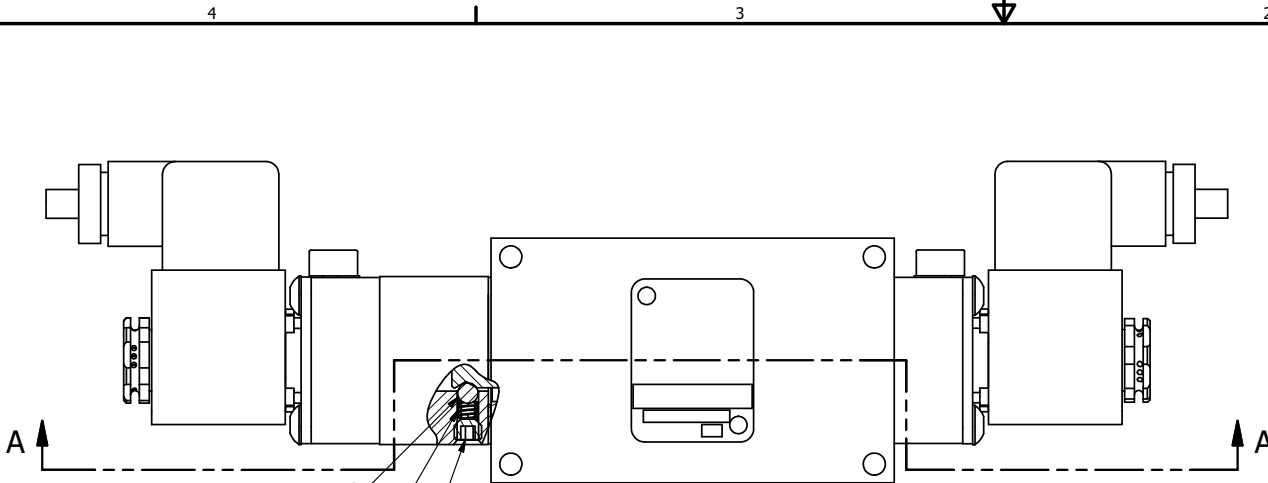
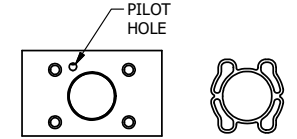

ALIGN PILOT AND SLOT IN ADAPTOR WITH GASKET IN BETWEEN, BOTH SIDES FOR EXTERNAL PILOT OPERATION - ROTATE ADAPTOR 180 DEGREES. REMOVE 1/8" NPTF PLUG AND SUPPLY 50-150 PSI TO 1/8" NPTF PILOT PORT IN ADAPTOR.

- NOTES:  
 1) ALWAYS GIVE VALVE MODEL AND PART NUMBER WHEN ORDERING PARTS.  
 2) LUBRICATE DETENT BALL, SPRING AND STUD.

PING AFTER INSTALLATION

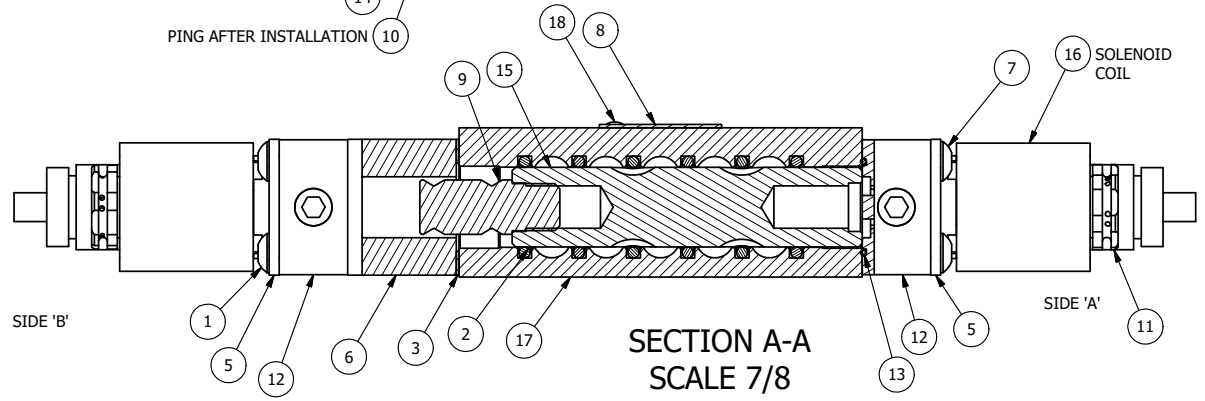

SECTION A-A  
SCALE 7/8  
VIEW FROM 3 PORT SIDE

18	2	V-212	SCREW, #2 X 3/16 DRIVE, TYPE U, OVAL HEAD, STAINLESS STEEL
17	1	B2-1E	BODY - SOLID, BUTTON BLEEDER, ANODIZED, 1/4" SIDE PORT VALVE
16	2	V-612-3	ATEX COIL 24 VDC WITH 3 METER CORD. NASS # 1215 30.1-001/6896.
15	1	S3R	SPOOL - SOLID, STANDARD, 2 POS, CLSD CTR, 1/4" & 3/8" VALVE
14	1	DS3	SPRING - DETENT, 1/4" & 3/8" VALVE
13	2	EMG3	GASKET - END MOUNT SOLENOID, BUNA-N, 1/4" & 3/8" VALVES
12	2	V-599-1	SOL OPER, END MOUNT, LOCKING O'RIDE
11	2	V-562	NUT, SOLENOID, SIDE EXHAUST
10	1	V-21	SCREW, 1/4-20 X 3/16, SOCKET SET, CUP POINT
9	1	PBS3-13-SS	STUD - POS. A & C. DETENT, STAINLESS STEEL, 1/4" & 3/8" VALVE
8	1	AN-114	NAMEPLATE, BLANK, FOR VALVES WITH SPRINGS OR DETENTS
7	4	V-584	SCREW, 10-24 X 1, BUTTON HEAD SOCKET CAP WITH MICROSPHERE APPLIED TO THREADS.
6	1	PEC3-18	ENDCAP, SPACER, DETENT, SOLENOID, 6061-T6, 1/4" & 3/8" VALVES
5	2	SEC3-7	PLATE, RE-INFORCEMENT, SOLENOID, STAMPED, 304 STAINLESS
4	1	V-14	BALL, CHROME STEEL 3/16 DIA, GRADE 25, FOR DETENT
3	1	BG3	GASKET - END CAP, 1/4" & 3/8" VALVE
2	6	V-39	O-RING, VITON, STD BODY, 1/4" & 3/8" VALVES
1	4	V-585	SCREW, 10-24 X 2-1/8, SOCKET BUTTON HEAD
FLG	QTY	PART NO	DESCRIPTION

LIMITS ON DIMENSIONS  
 UNLESS OTHERWISE SPECIFIED  
 2-PL DECIMAL ± .01  
 3-PL DECIMAL ± .005  
 FRACTIONAL ± 1/64  
 ANGULAR ± 1/2°



DRAWN: RMckenna DATE: 3/6/2020 CHECKED: KWaite DATE: 3/6/2020  
 SCALE: 1 : 1 SHEET: 1 OF 1 RELEASED: HWomack DATE: 3/6/2020

TITLE: 1/4" SIDE PORT, DBL SOL, 2 POS, DETENT, ATEX, 24VDC, LCKNG OVRD, SIDE VENT  
 PART NO.: ESS2TOCQ 24VDC  
 REV.: A

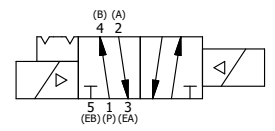

A	6/13/2020	CHNGD EMG3 GASKET TO BG3.
NO.	DATE	REVISION

4 | 3 | 2 | 1

THE INFORMATION CONTAINED WITHIN THIS DOCUMENT IS PROPRIETARY TO AAA PRODUCTS AND MAY NOT BE DISCLOSED WITHOUT PRIOR WRITTEN CONSENT

D:\Engineering\Product Valve Assembly\Standard\SS\DWG\ESS2TOCQ 24VDC.dwg